

SERIES 642 SPECIFICATIONS

Paired Panels

(Former Model Numbers 7500 & 6500)

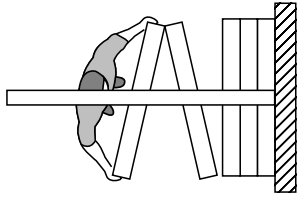

**Top Supported
Center Stack
Paired Panels**

Manually Operated

Maximum Height: 24'3" [7391]

Maximum Opening Width: Unlimited

STC Ratings: 41, 43, 47, 49, 51, 53

PRODUCT OVERVIEW

Select for Durability and Aesthetics: The 642 offers panel finishes for the ultimate in design flexibility. Even the frames may be color matched to coordinate with the faces. The 642 is a popular choice for hotel meeting rooms, convention centers, commercial facilities, or other high use facilities.

Standard Features: The panels are nominally 4" [101] thick, and have a 16 ga. steel frame. The top and bottom horizontal sound seals are retractable and provide floor clearance (to accommodate out-of-level floors). The faces may be covered from a wide selection of vinyl colors and patterns.

Paired Panels: Select for wall-to-wall space division. Panels are hinged in pairs allowing fast setup. They may be stacked at either or both ends of the track or in a "pocket". One or more pair of panels may be placed anywhere along the track for use as sight dividers.

How to Obtain: Hufcor partitions are sold, installed, and serviced by Custom Fold Doors, Inc., 1020 N. Hollywood Way #331, Burbank, Ca. 91505 Phone: (323) 849-3225 or (818) 3-6677, Fax: (818) 846-0744, www.customfold.net

Delivery: Panels are custom built for your specific project. Lead times vary due to seasonal fluctuations. Check with your Distributor for the current schedule.

Warranty: Track and panels are guaranteed for **two years** against defects in material and workmanship.

"Standard" Product Features and Benefits:

Look for these features when comparing similar products.

- Feature:** Protective vertical trim (Available option: no vertical face trim.)
Benefit: Trim protects the panel edges and faces plus it provides a handhold when moving panels.
- Feature:** Quick-set retractable top & bottom seals
Benefit: Retractable seals accommodate out-of-level floor conditions; provide constant force for consistent sound control and stability when the seals are set. When retracted, nothing drags on the floor or track when the panels are moved. Panels can be "locked" in place.
- Feature:** Retractable seals exert seal force
Benefit: Provides constant force against floor and track for optimum acoustics even on carpet or other porous floor materials. Maintains panel stability when the seals are set.
- Feature:** Waist high seal activator
Benefit: Fast, easy seal activation without bending or stooping.
- Feature:** Removable operating handle.
Benefit: Prevents unauthorized operation.
- Feature:** Expanding Jamb Closure (Lever Closure) Panel
Benefit: Exerts 250 lbs [113.4 kg] of force against the fixed wall. The compression creates tight panel joints for optimum sound control.
- Feature:** Interlocking, universal vertical seals
Benefit: Ensures panel-to-panel alignment and prevents sound leaks between panels.
- Feature:** Low profile hinges
Benefit: Safety and aesthetics - no unsightly hinges protruding from the panel faces.

www.customfold.net

Optional track systems, seals, and accessories enable the standard product to be modified for maximum versatility. See details provided or ask your Hufcor representative for the features you want.

GENERAL SPECIFICATIONS/SERIES 642

Paired Operable Partitions

PART 1 - GENERAL

1.01 DESCRIPTION

A. General

1. Furnish and install operable partitions and suspension system.
Provide all labor, materials, tools, equipment, and services for operable walls in accordance with provisions of contract documents.

1.02 RELATED WORK BY OTHERS

- A. Preparation of opening will be by General Contractor. Any deviation of site conditions contrary to approved shop drawings must be called to the attention of the architect.
- B. All header, blocking, support structures, jambs, track enclosures, surrounding insulation, and sound baffles as required in 1.04 Quality Assurance.
- C. Pre-punching of support structure in accordance with approved shop drawings.
- D. Paint or otherwise finishing all trim and other materials adjoining head and jamb of operable partitions.

1.03 SUBMITTALS

- A. Complete shop drawings are to be provided prior to fabrication indicating construction and installation details. Shop drawings must be submitted within 60 days after receipt of signed contract.

1.04 QUALITY ASSURANCE

- A. Preparation of the opening shall conform to the criteria set forth per ASTM E557 Standard Practice for Architectural Application and Installation of Operable Partitions
- B. The partition STC (Sound Transmission Classification) shall be achieved per the standard test methods ASTM E90.
- C. Noise isolation classifications shall be achieved per the standard test methods ASTM E336 and ASTM E413.
- D. Noise Reduction Coefficient (NRC) ratings shall be per ASTM C423.
- E. Rack testing for 10 years. (tensional strength stress test)
- F. The manufacturer shall have a quality system that is registered to the ISO 9001 standards.

1.05 PRODUCT DELIVERY, STORAGE, AND HANDLING

- A. Proper storage of partitions before installation and continued protection during and after installation will be the responsibility of the General Contractor.

1.06 WARRANTY

- A. Partition system shall be guaranteed for a period of two years against defects in material and workmanship, excluding abuse.

PART 2 PRODUCTS

2.01 ACCEPTABLE MANUFACTURERS

- A. Upon compliance with all of the criteria specified in this section, Manufacturers wishing to bid products equal to the product specified must submit to the architect 10 days prior to bidding complete data in support of compliance and a list of three past installations of products similar to those listed. The submitting manufacturer guarantees the proposed substituted product complies with the performance items specified and as detailed on the drawings.

2.02 MATERIALS

- A. Product to be top supported Series 642 paired panels as manufactured by Hufcor Inc.
 1. Panels shall be nominally 4" [101] thick, to 48" [1219] in width, and hinged in pairs.
 2. Panel faces shall be laminated to appropriate substrate to meet the STC requirement in 2.04 Acoustical Performance.
 - a. Optional face material (Not all substrates are available for all STC ratings. Consult your Hufcor Distributor for more information):
 - Steel
 - Non-steel
 - Medium Density Fiberboard
 - b. Horizontal Splice: Heights over 16'3" [4953] with non-steel faces require a structural splice placed at approximately 12'3" [3734] from the floor.
 3. Frames shall be of 16 gauge [1.42mm] painted steel with integral factory applied aluminum vertical edge and face protection.
Optional: Face finish shall wrap around the vertical panel edges and

provide no protective vertical face trim.

4. Vertical sound seals shall be of tongue and groove configuration, ensure panel-to-panel alignment and prevent sound leaks between panels.
 6. Horizontal top seals shall be retractable, provide 1" [25] nominal operating clearance, and exert upward force when extended. All panels, including pass door panels and lever closure panels must have retractable top and bottom seals.
 7. Horizontal bottom seals shall be retractable, provide up to 2" [51] nominal operating clearance, and exert downward force when fully extended. Optional:
 - a. Horizontal bottom seals shall be fixed continuous contact 4-finger vinyl.)
 7. Horizontal trim shall be of aluminum.
 8. Low profile hinges on basic panels shall be of steel and project no more than 1/4" [6] beyond panel faces. Each pair of panels to have a minimum of three hinges.
- B. Weight of the panels shall be 5.8-10.9 lbs./sq. ft. [328.2-53.2 kg/sq.m] based on options selected.
- C. Suspension system:
 1. Track shall be of clear anodized architectural grade extruded aluminum alloy 6063-T6. Track design shall provide precise alignment at the trolley running surfaces and provide integral support for adjoining ceiling, soffit, or plenum sound barrier. Track shall be connected to the structural support by pairs of minimum 3/8" [10] dia. threaded steel hanger rods. Guide rails and/or track sweep seals shall not be required.
 - a. Each panel shall be supported by one 4-wheeled carrier. Wheels to be of hardened steel ball bearings encased with molded polymer tires.
 2. Plenum closure (by others): Design of plenum closure must permit lifting out of header panels to adjust track height. Plenum closure required for optimum sound control of partition.
 3. Option (available for select layouts consult your Hufcor Distributor): The panels shall be supported by the Unispan pre-engineered truss and post system fabricated of steel and aluminum. Unispan is attached to the building structure for lateral support only. The load of the truss and partition is supported by end columns and the system transfers the partition weight to the floor.
- D. Available Accessories/Options
- E. Finishes
 1. Face finish shall be: **(select as required)**:
 - a. Factory applied reinforced vinyl fabric with woven backing, weighing not less than 15 oz. per lineal yard [465 g/m]. Color shall be selected from manufacturer's standard color selectors.
 - b. Standard upgrade fabrics (color shall be selected from manufacturer's standard color selector):
 - (1) Factory applied vertical ribbed carpet (N.R.C. .20)
 - (2) Factory applied 100% polyolefin stain resistant fabric
 - (3) DIVISIONS™ stain repellent fabric by Milliken
 - c. Optional:
 - (1) Customer selected (requires factory approval for manufacturing compatibility)
 - (2) Unfinished for field decoration
 - (3) Wood veneer (factory installed on trimmed models)
 - (4) High pressure laminate (factory installed on trimmed models)
 2. Exposed metal trim and seal color shall be **(select from Hufcor's Standard Trim selector)**:
 - a. Lamb's Wool (standard)
 - b. Brown (standard)
 - c. Gray (standard)
 - d. Custom powder coated (optional upgrade for metal trim)
 3. Aluminum track shall be clear anodized
 - a. Optional upgrade:
 - (1) Custom anodized
 - (2) Custom powder coated
- F. Available Accessories/Options
 1. ADA compliant pass door of the same thickness and construction as the basic panels. Pass door panel legs require bottom seals that provide downward force to maintain stability during door operation. Pass door leaf has perimeter trim to protect face finish and to provide visual identification as required by International Building Code. Pass door leaf incorporates a self-adjusting retractable bottom seal providing sound control when door is closed.

HORIZONTAL SECTION WITH TRIM

Final partition closure using an Expanding Jamb (Lever Closure). Solid blocking is required at both ends to withstand 250 lbs. [113.4 kg] of lateral force.

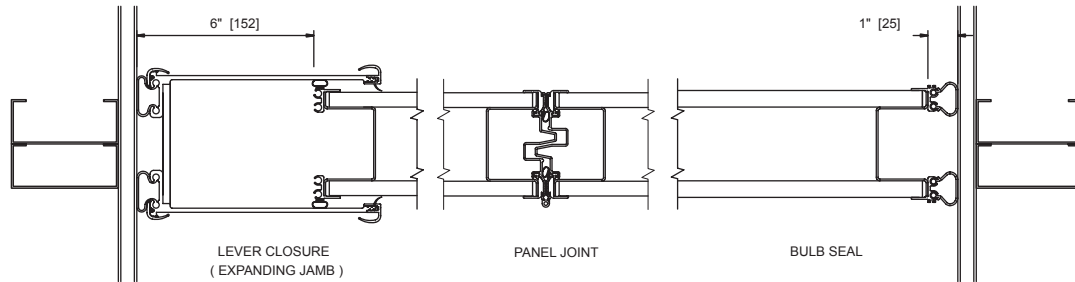

Optional: No vertical face trim on panel joint.

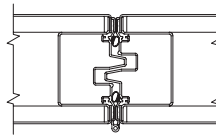

Optional: Wall Jamb Assembly

No Scale

OPTIONS & ACCESSORIES

ELEVATION

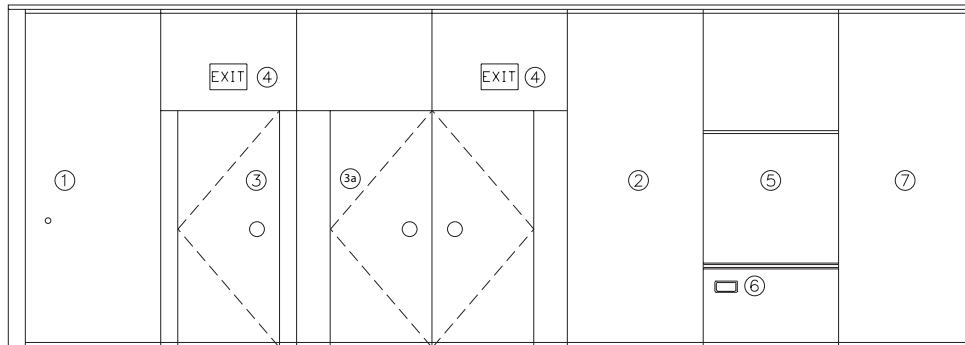

1. **Expanding Jamb Closure (Lever Closure) Panel** - Expanding jamb exerts 250 lbs. [113.4kg] force against adjacent wall for optimum sound control.
2. **Basic Panel**
3. **ADA compliant** - Single 3/0 x 7/0 [914 x 2132] or 3/0 x 6/8 [914 x 2030]. Of the same construction, thickness, and finish as the basic panels. Push/pull latching handle. Options include key lock, windows, and automatic door closer. No threshold is required.
 - 3a. Double doors ("batwing") also available.
4. **Exit Sign** - Recessed or surface mounted, self-illuminated.
5. **Work Surfaces** 4'0" [1219] high x panel width, recessed, mounted approx. 30" [762] above the floor:
 - a. Markerboard and projection/writing surfaces (from Hufcor standard color selector).
 - b. Tackboards of 2mm cork board covered with vinyl (from Hufcor standard color selector).
 - c. Chalk/marker tray (standard on chalk and projection/writing boards).
6. **Recessed Eraser Pocket** (8" x 2" x 1-1/4" deep [203 x 50 x 31]).
7. **Leadb** with bulb seal to prevent sound leaks at adjacent wall.

Optional: Lead panel closure to 4" adjustable, full height, acoustic wall jamb assembly.

Paired Operable Partitions

STACK DIMENSIONS

The following dimensions are based on standard construction with vinyl faces. Optional construction and/or face covering may increase the requirement

Single Opening Using Panel

- A = Stack Depth, 4-1/4" [108] per panel plus 1" [25]
- B = Stack Width:
 - No Pocket: Panel width + 3" [76].
 - Pocket without pocket doors: Panel width + 7" [178]

Optional design (at both ends).
 (same formula at each end as single).

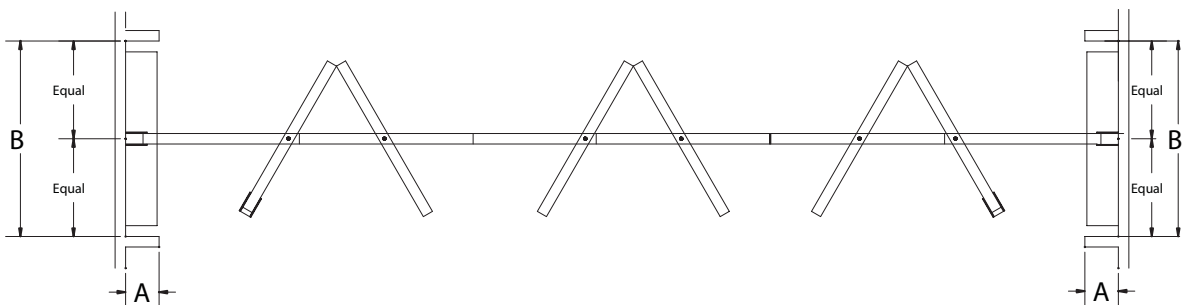

HANGER ROD LAYOUT - For Type 38, 40, 41, 43, 47, 49, 51, 53

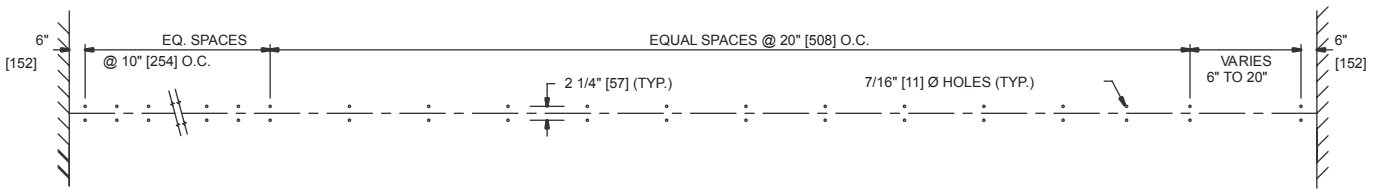

HANGING WEIGHT		
STC	Lbs./Sq. Ft.	Kg./Sq. M
41	5.8	28.2
43	7.8	37.8
47	8.0	38.7
49	8.5	41.2
51	9.5	46
53	10.9	53.2

OPTIONS

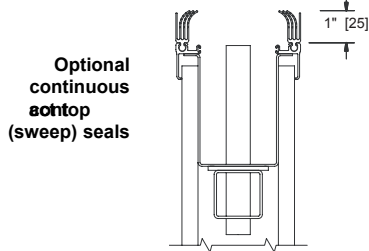

Optional continuous acontop (sweep) seals

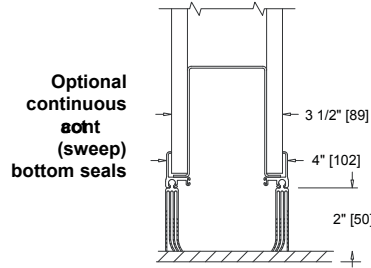

Optional continuous acont bottom seals

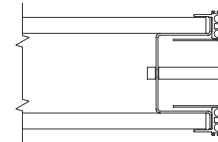

Optional finished end cover - provides finished panel end when partition run does not extend from wall-to-wall.

OPTIONAL TRACKS - Alternate track or track may be used providing the height and weight limit with manufacturer

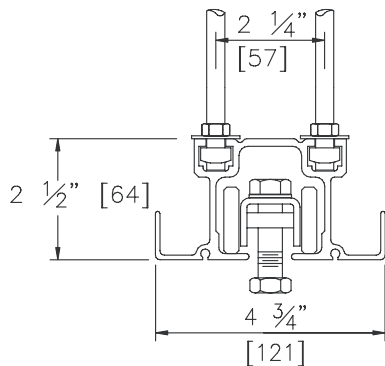

Type A Track T
Optional for panel weights to 400 lbs. [182 kg].

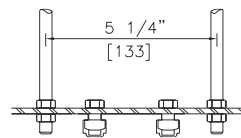

Optional suspension bracket available for 5-1/4" [133] spacing.

Custom Fold Doors, Inc.
1020 N. Hollywood Way #331
Burbank, Ca. 91505
Phone: (323) 849-3225 or (818) 563-6677, Fax: (818) 846-0744
www.customfold.net